

# 400G QSFPDD immersion cooling extender

## FSQE-PC401-DXX

### Features

- ◆ Compliant QSFP-DD MSA
- ◆ Typical insertion loss less 5dB@13.28GHz with 0.5m length
- ◆ 100ohm differential impedance system
- ◆ 3.3V power supply
- ◆ I2C R/W function
- ◆ Status indicators with LED
- ◆ 3.3V/0.85W fan for contact cooling
- ◆ Low EMI radiation and crosstalk
- ◆ RoHS compliant(lead free)



### Applications

- ◆ Extend 400G QSFP-DD transceiver/AOC for liquid immersion link environment
- ◆ Protect device QSFP-DD SMT connector
- ◆ provide I2C R/W and some status indicators with LED

Fiberstamp can offer rich experience of immersion solution, that includes different form and speed transceivers/AOC/product. Fiberstamp 400G QSFP-DD immersion cooling extender (GLQE-PC401-DXX) is an important part of liquid immersion solution, normal QSFP-DD form transceiver/AOC can be used for immersion environment with this product. This product include extender cage, cable, QSFP-DD housing three parts, the cable length can be customized no more than 0.5m for extension, that can avoid the optical lens/engine/interface exposure to the liquid indirectly.

### Description

In addition, this product can provide I2C read/write, also can show the status indicators with LED for low speed electrical hardware pins. When insertion and removal frequently, this product can effectively protect the QSFP-DD SMT connector of switch/NIC.

### Liquid cooling Advantage

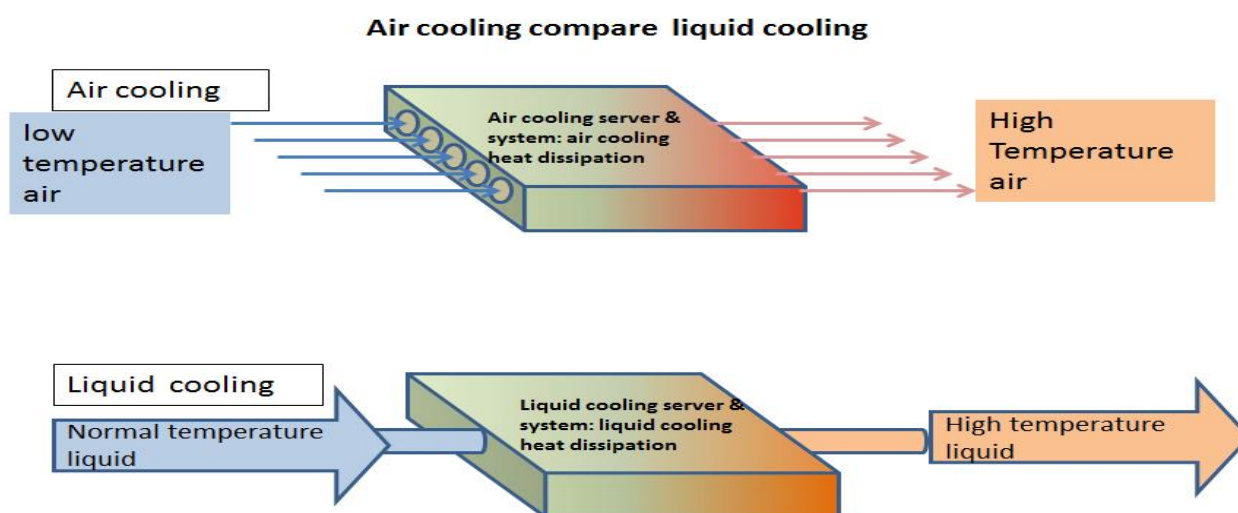

Figure 1. Liquid cooling advantage

As the requirement of data traffic keeping growth and the heat flux emitted by datacenter internal chips increases constantly, traditional air cooling methods are under pressure. Liquid cooling technologies removes the heat more efficiently with dielectric fluids that have high heat capacity to improve the efficiency of energy in datacenter. Fiberstamp solved the lack of optical transceivers which perform reliability in immersion even liquid immersion depth up to 10m, the Liquid cooling optical series transceiver is suitable for liquid cooling server & system, this series product are compatible with fluorinated liquid and mineral oils well.

Immersion cooling extender can also be a important role in liquid immersion solution, existing normal QSFP –DD form transceiver/AOC can be adapted for immersion indirectly.

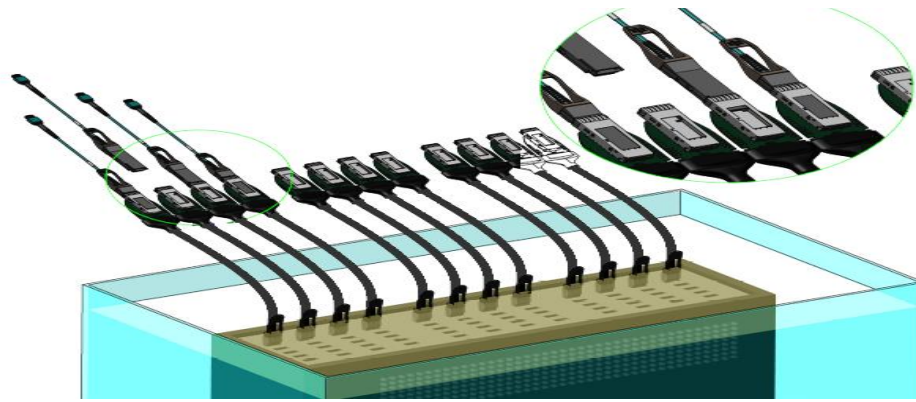

Figure 2 Immersion cooling extender under liquid

**Absolute Maximum Ratings**

Parameter	Symbol	Min	Max	Unit
Storage Temperature	T <sub>s</sub>	-20	85	°C
Case Operating Temperature	T <sub>c</sub>	0	70	°C
Humidity (non-condensing)	Rh	5	95	%

**Recommended Operating Conditions**

Parameter	Symbol	Min	Typical	Max	Unit
Operating Case Temperature	T <sub>c</sub>	-20		70	°C
Baud Rate per Lane	fd		26.56		GBaud/s
Humidity	Rh	5		85	%

**Main Part assembly**



FP-DD extender main part assembly

Figure 3 QS

**Extender contact Pin Description**

Pin	Logic	Symbol	Name/Description
1		GND	Module Ground <sup>Note5</sup>
2	CML-I	Tx2-	Transmitter inverted data input
3	CML-I	Tx2+	Transmitter non-inverted data input
4		GND	Module Ground <sup>Note5</sup>
5	CML-I	Tx4-	Transmitter inverted data input
6	CML-I	Tx4+	Transmitter non-inverted data input
7		GND	Module Ground <sup>Note5</sup>
8	LVTTTL-I	MODSEIL	Module Select <sup>Note6</sup>
9	LVTTTL-I	ResetL	Module Reset <sup>Note6</sup>
10		VCCR <sub>x</sub>	+3.3V Power Supply
11	LVC <sub>MOS</sub> -I	SCL	2-wire Serial interface clock <sup>Note6</sup>
12	LVC <sub>MOS</sub> -I/O	SDA	2-wire Serial interface data <sup>Note6</sup>
13		GND	Module Ground <sup>Note5</sup>
14	CML-O	RX3+	Receiver non-inverted data output
15	CML-O	RX3-	Receiver inverted data output
16		GND	Module Ground <sup>Note5</sup>

17	CML-O	RX1+	Receiver non-inverted data output
18	CML-O	RX1-	Receiver inverted data output
19		GND	Module Ground <sup>Note5</sup>
20		GND	Module Ground <sup>Note5</sup>
21	CML-O	RX2-	Receiver inverted data output
22	CML-O	RX2+	Receiver non-inverted data output
23		GND	Module Ground <sup>Note5</sup>
24	CML-O	RX4-	Receiver inverted data output
25	CML-O	RX4+	Receiver non-inverted data output
26		GND	Module Ground <sup>Note5</sup>
27	LVTTL-O	ModPrsL	Module Present, internal pulled down to GND
28	LVTTL-O	IntL	Interrupt output, should be pulled up on host board <sup>2</sup>
29		VCCTx	+3.3V Transmitter Power Supply
30		VCC1	+3.3V Power Supply
31	LVTTL-I	LPMMode	Low Power Mode <sup>Note6</sup>
32		GND	Module Ground <sup>Note5</sup>
33	CML-I	Tx3+	Transmitter non-inverted data input
34	CML-I	Tx3-	Transmitter inverted data input
35		GND	Module Ground <sup>Note5</sup>
36	CML-I	Tx1+	Transmitter non-inverted data input
37	CML-I	Tx1-	Transmitter inverted data input
38		GND	Module Ground <sup>Note5</sup>
39		GND	Module Ground <sup>Note5</sup>
40	CML-I	Tx6-	Transmitter inverted data input
41	CML-I	Tx6+	Transmitter non-inverted data input
42		GND	Module Ground <sup>Note5</sup>
43	CML-I	Tx8-	Transmitter inverted data input
44	CML-I	Tx8+	Transmitter non-inverted data input
45		GND	Module Ground <sup>Note5</sup>
46		Reserved	
47		TBD	For future use
48		VCC	+3.3V Receiver Power Supply
49		TBD	For future use
50		TBD	For future use
51		GND	Module Ground <sup>Note5</sup>
52	CML-O	RX7+	Receiver non-inverted data output
53	CML-O	RX7-	Receiver inverted data output
54		GND	Module Ground <sup>Note5</sup>
55	CML-O	RX5+	Receiver non-inverted data output
56	CML-O	RX5-	Receiver inverted data output
57		GND	Module Ground <sup>Note5</sup>
58		GND	Module Ground <sup>Note5</sup>
59	CML-O	RX6-	Receiver inverted data output
60	CML-O	RX6+	Receiver non-inverted data output
61		GND	Module Ground <sup>Note5</sup>
62	CML-O	RX8-	Receiver inverted data output
63	CML-O	RX8+	Receiver non-inverted data output
64		GND	Module Ground <sup>Note5</sup>
65		NC	No connect
66		TBD	For future use
67		VCC	+3.3V Power Supply
68		VCC	+3.3V Power Supply
69		TBD	For future use
70		GND	Module Ground <sup>Note5</sup>
71	CML-I	Tx7+	Transmitter non-inverted data input
72	CML-I	Tx7-	Transmitter inverted data input
73		GND	Module Ground <sup>Note5</sup>
74	CML-I	Tx5+	Transmitter non-inverted data input
75	CML-I	Tx5-	Transmitter inverted data input
76		GND	Module Ground <sup>Note5</sup>

Note:

1. Module circuit ground is isolated from module chassis ground within the module.
2. Open collector should be pulled up with 4.7K to 10K ohms on host board to a voltage between 3.15V and 3.6V.



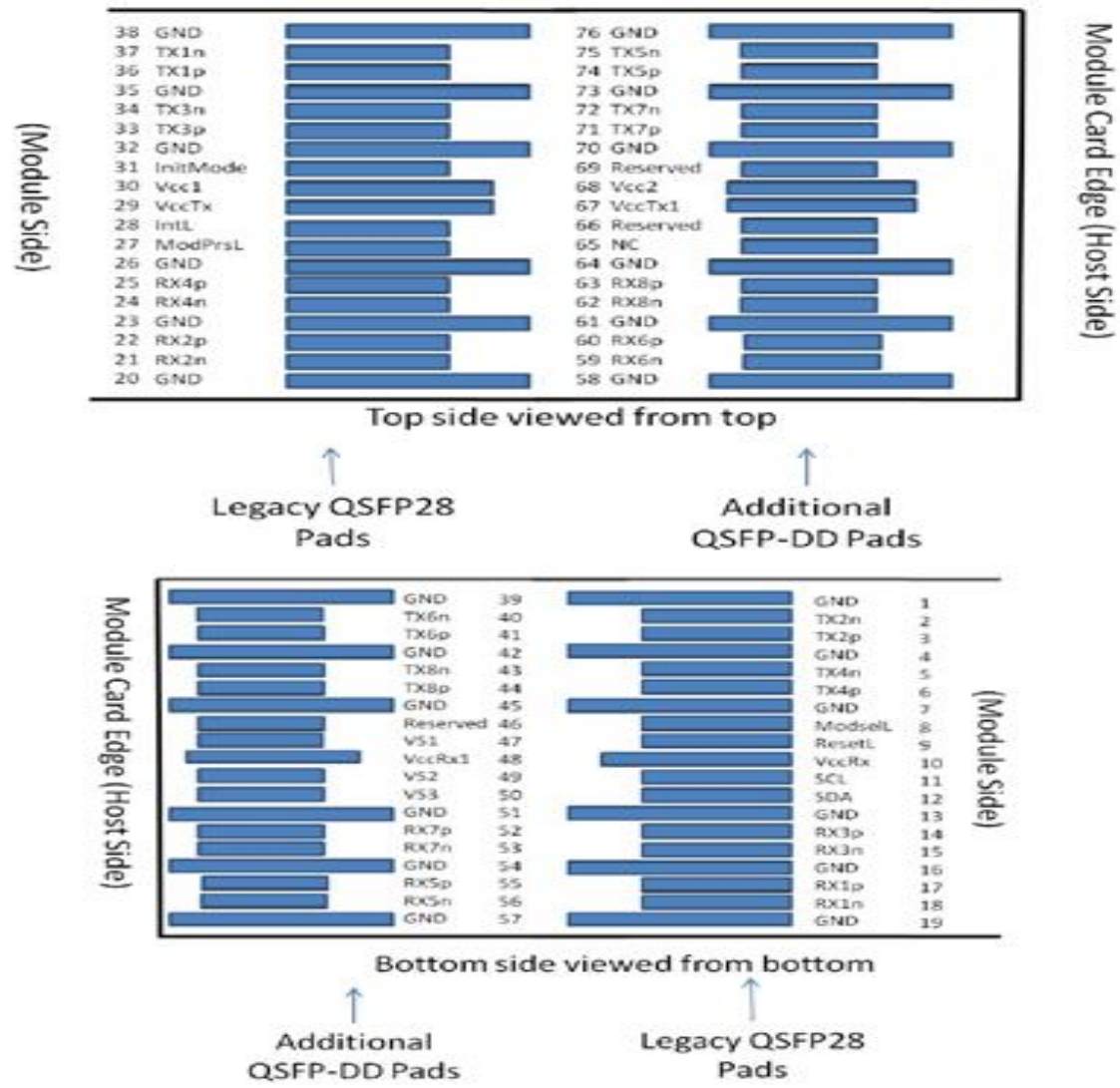

Figure 4. Extender housing QSFP-DD SMT connector pin

Mechanical Dimensions

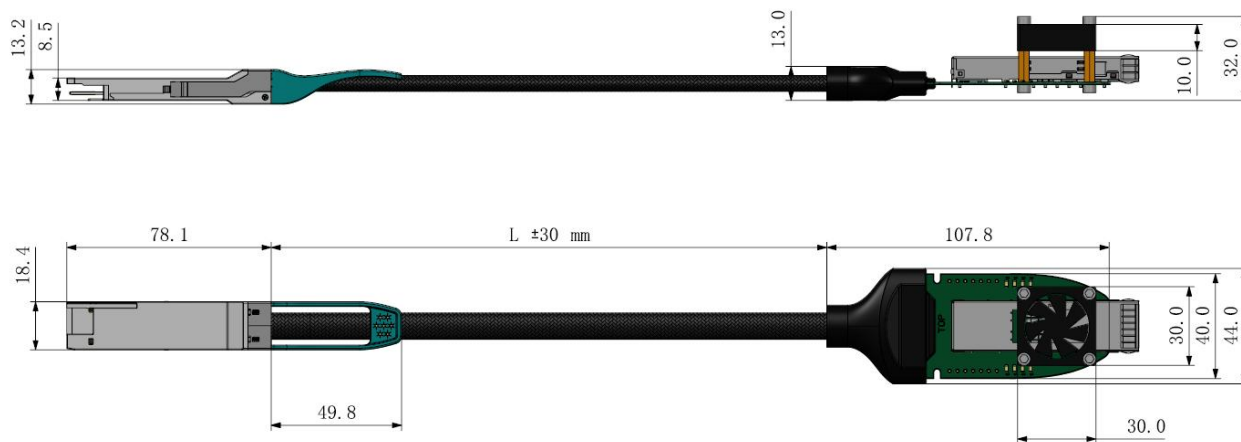

Figure 5. Mechanical Specifications

Wiring Patterns and connection diagram



WIRING TABLE				
P1 (QSFP PLUG)			P2 (QSFP RECEPTACLE)	
01	GND	↔	01	GND
02	TX2n	↔	02	TX2n
03	TX2p	↔	03	TX2p
04	GND	↔	04	GND
05	TX4n	↔	05	TX4n
06	TX4p	↔	06	TX4p
07	GND	↔	07	GND
08	ModseIL	↔	08	ModseIL
09	ResetL	↔	09	ResetL
11	SCL	↔	11	SCL
12	SDA	↔	12	SDA
13	GND	↔	13	GND
14	RX3p	↔	14	RX3p
15	RX3n	↔	15	RX3n
16	GND	↔	16	GND
17	RX1p	↔	17	RX1p
18	RX1n	↔	18	RX1n
19	GND	↔	19	GND
20	GND	↔	20	GND
21	RX2n	↔	21	RX2n
22	RX2p	↔	22	RX2p
23	GND	↔	23	GND
24	RX2n	↔	24	RX2n
25	RX2p	↔	25	RX2p
26	GND	↔	26	GND
27	ModPrsL	↔	27	ModPrsL
28	IntL	↔	28	IntL
29	VccTx	↔	29	VccTx
30	Vcc1	↔	30	Vcc1
10	VccRx	↔	10	VccRx
31	LPMode	↔	31	LPMode
32	GND	↔	32	GND
33	TX3p	↔	33	TX3p
34	TX3n	↔	34	TX3n
35	GND	↔	35	GND
36	TX1p	↔	36	TX1p
37	TX1n	↔	37	TX1n
38	GND	↔	38	GND
39	GND	↔	39	GND
40	TX6n	↔	40	TX6n
41	TX6p	↔	41	TX6p
42	GND	↔	42	GND
43	TX8n	↔	43	TX8n
44	TX8p	↔	44	TX8p
45	GND	↔	45	GND
46	Reserved		46	Reserved
47	VS1	↔	47	VS1
48	VCCRx1	↔	48	VCCRx
49	VS2	↔	49	VS2
50	VS3	↔	50	VS3
51	GND	↔	51	GND
52	RX7p	↔	52	RX7p
53	RX7n	↔	53	RX7n
54	GND	↔	54	GND
55	RX5p	↔	55	RX5p
56	RX5n	↔	56	RX5n
57	GND	↔	57	GND
58	GND	↔	58	GND
59	RX6n	↔	59	RX6n
60	RX6p	↔	60	RX6p
61	GND	↔	61	GND
62	RX8n	↔	62	RX8n
63	RX8p	↔	63	RX8p
64	GND	↔	64	GND
65	NC		65	NC
66	Reserved		66	Reserved
67	VccTx1	↔	67	VccTx
68	Vcc2	↔	68	Vcc1
69	Reserved		69	Reserved
70	GND	↔	70	GND
71	TX7p	↔	71	TX7p
72	TX7n	↔	72	TX7n
73	GND	↔	73	GND
74	TX5p	↔	74	TX5p
75	TX5n	↔	75	TX5n
76	GND	↔	76	GND

Figure 6. Wiring Patterns

Extender housing pin and parts

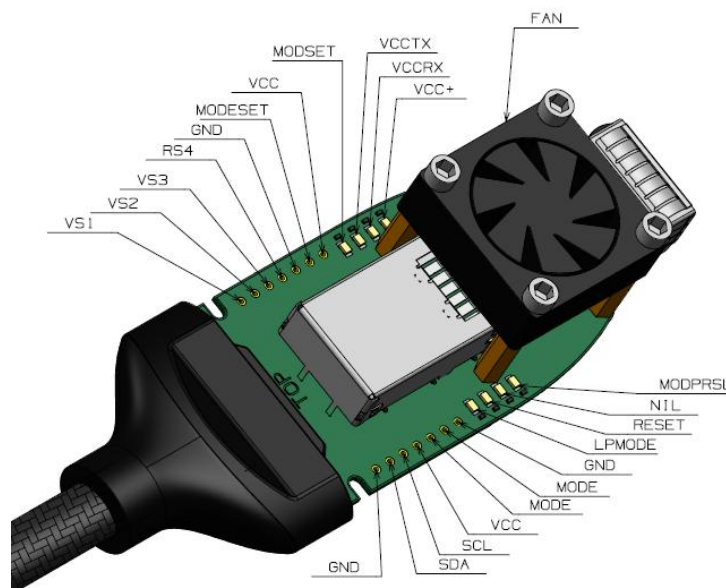

Figure 7. Extender housing pin and parts

Regulatory Compliance

Fiberstamp's 400GbE immersion cooling extender They meet the requirements of the following standards:

Feature	Standard
---------	----------



Electrical Safety	EN 62368-1: 2014 IEC 62368-1:2014 UL 62368-1:2014
Environmental protection	Directive 2011/65/EU with amendment(EU)2015/863
CE EMC	EN55032: 2015 EN55035: 2017 EN61000-3-2:2014 EN61000-3-3:2013
FCC	FCC Part 15, Subpart B; ANSI C63.4-2014

**Ordering information**

Part Number	Length	Description
FSQE-PC401-D05	50cm	400G QSFP-DD extender with high speed cable, with PET jacket , with fan,0.5meter length with connector and cage.

The length (meter) and wire gage of GLQE-PC401-DXX is decimal and can be customizable, the default AWG is 26AWG in 0.5m length.

**Important Notice**

Performance figures, data and any illustrative material provided in this data sheet are typical and must be specifically confirmed in writing by Fiberstamp before they become applicable to any particular order or contract. In accordance with the Fiberstamp policy of continuous improvement specifications may change without notice.

The publication of information in this data sheet does not imply freedom from patent or other protective rights of Fiberstamp or others. Further details are available from any Fiberstamp sales representative.

E-mail:[sales@Fiberstamp.com.cn](mailto:sales@Fiberstamp.com.cn)

Official Site:<http://www.Fiberstamp.com>

**Revision History**

Revision	Date	Description
V0	Mar-12-2024	Advance Release.

